

GTB4R //X

Gasoline System Test Bench



**The Optimum
Gasoline Specialists GDi Solution**

The Professional's Service Station
for All Types and Makes GDI systems.

GTB4R //X



// 1200 Bar

**4 GDi injectors.
Capable
for all EU6
technologies**

A Revolution in GDi Test Benches

Our qualified team, know-how
and pioneering thinking developed
the New Powerful GTB.4R|X

GTB4R //X

an OE Approved Solution

The New GTB.4R|X is a unique Standalone Gasoline Injector Testbench capable to thoroughly Test, Service and code every possible GDi in the Market today.

The machine's Innovative technology is already in compliance with all EU6 Standards and requirements, meantime is prepared for future upgrades.

#carbonzappXseries



////// Evaluation of the New GTB.4R|X

5-7 minutes testing time for:

4 GDi injectors (All Brands and Types). Capable for all EU6 technologies

Precise, repeatable and rapid Gasoline Injectors Testing

Coding Capable for all Types of GDi's (Energy Controlled or Volume Metering types)

Flushing and Servicing options for GDi injectors

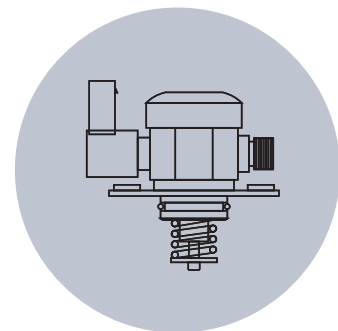

GDi Pump testing on a conventional bench as an external control & measurement*

*New database and Coding is continuously being updated to new EU6 applications

Applications

Gasoline Passenger cars

Gasoline Light Duty vehicles

Gasoline Outboard motors

Alternative Fuels engines

Features

Xtremely Fast Testing Times without any Compromise

New Design for every Service Station

Optimized Working Area to reduce Injector Set-up Times

1200Bar Capable Test Bench

EU6 Systems Testing and Coding

CloudX Capabilities

CloudX™

Cloud Based Technology

Industry 4.0 Complaint

Remote Sync & Backup

Machine Fleet Management

Online Features Activation

Instant Troubleshooting & Support

AZO Software v3.0

Powered by CloudX

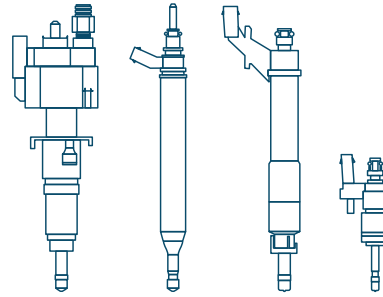

DGS

Diesel & Gasoline
Specialists Solutions

Ergonomic, Fast and Easy Injector Clamping device to minimize mounting times.

Fully Adjustable height for all types of CR injectors.

Utilizes a spring-loaded injector holder to ease the operation of the user.

Quick access to all inline filters for fast check-up and replacement located within your working area. A mess-free compartment to work at, continuously draining to the waste tank.

Advanced Testing capability for all brands and types available in the market today. Bosch, Denso, Delphi, Continental /VDO, Hitachi-HTC, Magneti Marelli and more added every day...

Coding capability for Siemens/ VDO and for the newer* generation EU6 available in the market today.

Advanced water-cooling or air-cooling system to optimize long term nonstop operation at all environmental conditions.

Live Response Time Measurement at every test plan

Adaptability for every type of Gasoline Injectors in the market

Continuous Database updates and new Software capabilities to meet the market needs.

Android Powered 15.6' HMI with unlimited flexibility and connectivity competencies.

Part Number		GTB.4RX
	Standalone Add-On Cooling Type	● - [A / W]
TYPE	Test Bench Simulator / Controller Cambox Service / Diagnostic Unit	● - - -
USER LEVEL	Diesel / Gasoline Specialists Workshop / Garage Test Slots [injectors / Pumps]	● ○ [4 / 1]
SYSTEMS / [TESTING MINUTES]	CRDi / Smart Injectors [1 / 4] GDi Injectors [1 / 4] CR Pumps [1] GDi Pumps [1] EUI / EUP / Smart EUP [1] HEUI [1 / 4] Gasoline Injectors [1 / 4] LPG / CNG Injectors [1 / 4] Gasoline /Other Engines Diesel Engines Gasoline/Diesel Fuel Systems	- ● / [-/6] - □ / [5] - - - □ □ - - -
APPLICATIONS	Passenger Car / HEV / PHEV Motorcycles Racing (Gasoline) Light Duty Medium Duty Heavy Duty / Industrial Marine EV (Electric Vehicles)	● ● ● ● - - - - -
FEATURES	Coding Capability for Passenger Car / Light Duty Coding Capability for Medium/Heavy Duty Authorized Solutions	□ - -
MEASUREMENT SENSORS	XKM DFM500 DFM50 Volumetric Tubes	4 - - -
SYSTEM PRESSURE	Max (BAR) Source Source Power (HP)	1200 MOTOR 4,8
CHARACTERISTICS	Response Sensor Response Sensor HD Pressurized Return Hoses / PIRV's Exclusive Return Hoses Kit Spray Chamber Heavy Duty Injector Adapters & Fittings Heavy Duty Pump Adapters & Fittings Exclusive Electrical Connectors Mains Power 50/60Hz /1-Phase 100-250VAC Mains Power 50/60Hz /3-Phase/PE 380-480VAC Air-Supply (Bar / L/min) Water Cooling (requires connection) Air Cooling Tank Capacity [testing / flushing] HMI (Inches) Touchscreen Flushing / MACC Protective Cover Calibration Oils Ultrasonic Bath	□ - - - ○ - - - ○ ● - - - - - - - - - ● [30 / -] 15,6 ● □ / - ● ○ ○
PACKAGING	Width (mm) Depth (mm) Height (mm) Weight (kg)	920 1160 1870 352

EXPLANATIONS

- : Capable / Standard Equipped
- : Capable / Optionals required
- : Optional
- : N/A
- A: Air Cooling
- W: Water Cooling

MEASUREMENT SENSORS

XKM (Dynamic Meas. Sensor): High Accuracy; ± 0.1%, Exceptional Repeatability ±0.05%, Measur. Range: 1-10000ml/min
DFM 500 (Dynamic Measurement Sensor): Accuracy: ± 1%, Repeatability 0.5%, Measurement range: 5-500l/min
DFM 50 (Dynamic Measurement Sensor): Accuracy: ± 1%, Repeatability 0.5%, Measurement range: 0.5-50l/min
Volumetric Tubes (Static Analog Measurement): Accuracy: 1ml, Measurement range: 0.5-65ml

APPLICATIONS

Passenger Car/ Motorcycles: Volumes up to 120mm³/H
Light Duty: Volumes up to 200mm³/H
Medium Duty: Volumes up to 300mm³/H
Heavy Duty: Volumes up to 650mm³/H
Marines: Volumes up to 1500mm³/H

PRESSURE SOURCES

Air: Air Driven High Pressure Pump
Motor: Motor Driven High Pressure CR Pump
External: Pressure coming from another Test Bench or external source
Electr. Pump: Fuel Injection system or Industrial Application
Electrical Pump 12VDC
-: No Pressure Source



Import i dystrybucja w Polsce

Gładyszek Sp. J.
Aleja Generała Tadeusza Bora-Komorowskiego 11
31-476 Kraków
tel: +48 12 412 99 89

biuro@cartechnik.pl

gladysek.pl
carbonzapp.pl

Main Offices & Production Plant
364 Varis-Koropiou Ave. Koropi
194 42 Athens, Greece

Headquarters
A.I.S. GmbH
75438 Knittlingen, Germany

email contact@carbonzapp.com
tel +30 210 9856110
fax +30 210 9928655

carbonzapp.com